

CONTROL 
TECHNIQUES



HVAC DRIVE H300

EFFICIENCY AND RELIABILITY IN HVAC

DRIVE OBSESSED

HVAC DRIVE H300

THE SPECIALIST HVAC

DRIVE FROM THE

DRIVE SPECIALISTS

Control Techniques' HVAC Drive H300 variable frequency AC drive (VFD) is the result of extensive research and builds on our vast experience of the HVAC market.

The HVAC Drive H300, part of the newly introduced Specialist series of industry-specific drive technologies, builds on our company's five decades of drives expertise, delivering precise, dependable flow control.

The HVAC Drive H300 dimensions are among the smallest in its class at every power rating. This saves valuable building real estate, makes the drives easy to handle, and maximizes mounting flexibility.



Free 5 year warranty*

To share our confidence in the reliability of Control Techniques, drives in the H300 range are eligible for Control Techniques' extended warranty, at no extra cost.

It is a testament to our exceptional track record for reliability, giving you total peace of mind that your investment is protected and your site will continue to run uninterrupted.

*Warranty terms and conditions apply.

The drive for building HVAC

The HVAC Drive H300 has been designed to meet the needs of:

Consultants and design engineers

- All the necessary features to meet your building HVAC project specification requirements.
- A highly reliable product and support service: Simply specify, install and forget.

Contractors

- Fast, easy and secure installation, commissioning and maintenance.

Owners of commercial buildings

- Achieves maximum building occupant comfort.
- Optimum energy saving and value with rapid ROI.

A COMPLETE HVAC BUILDING AUTOMATION SOLUTION

The HVAC Drive H300 is optimised for fan/compressor control in HVAC applications and has all the features you would expect from a dedicated HVAC drive and more:



BACnet MS/TP onboard

Building automation systems

- Seamless integration with Building Automation Systems with the following onboard communications supported:
 - i. BACnet, conformance tested to guarantee reliable operation
 - ii. Modbus RTU communications

Custom software

- Flexibility without a Building Management System with optional modules for running custom application software.

Fire mode

- The HVAC Drive H300 has onboard Fire mode which allows the drive to continue running uninterrupted in the event of a fire. It can allow the safe extraction of smoke while the drive's other functions are maintained.

High efficiency operating modes

- Quiet operation with Rotor Flux Control modes, high switching frequencies (up to 16 kHz).
- Intelligent 10 speed drive cooling fan with minimum noise operation.

Conformal coated PCB

- High product reliability with conformally coated PCBs as standard.

Compact dimensions

- Among the most compact VFD in its class at every frame size, maximizing mounting flexibility.

Dual PID

- Built-in dual process PID loops that can operate independently or be combined to provide more complex functionality.



CONTROL TECHNIQUES

Energy efficiency as standard

- Exponential energy savings through fitting a Control Techniques Variable Frequency Drive into the application.
- HVAC Drive H300 provides high energy efficiency, up to 98% where very little energy is lost in the conversion.
- Motor control of super high efficiency sensor-less permanent magnet motors.
- Dynamic Volts/Hertz energy optimization minimises power loss under low load conditions.

Energy savings

- Energy savings features promise a low total cost ownership:
 - i. Sleep, Wake & VFD standby modes ensure minimal wasted energy
 - ii. Onboard power metering includes a cost per kWh function to track operating costs
 - iii. Energy savings verified with CT Energy Efficiency Calculator tool

Thermistor monitoring

- A temperature sensor input is available which can directly provide an analogue input without a transducer for control of fans and compressors.

CONTROL TECHNIQUES IN HVAC

The HVAC & Refrigeration market was identified as the largest single segment for growth within the top 8 growing Motor Drive Machinery Markets in 2020*

As HVAC & Refrigeration global demands increase, so does the need for efficient operation and saving energy.

Drives are highly concentrated in the HVAC & Refrigeration market and play a key part in reducing energy consumption – Control Techniques' HVAC Drive H300 drives builds on decades of expertise to provide flexibility and reliability within this rapidly growing market.

Extreme operating conditions

Operate in conditions from -20°C to 55°C* (40 °C as standard, above with derating).

Extended connectivity

Extended connectivity with SI option modules (POWERLINK, EtherNet/IP, Modbus TCP/IP, EtherCAT, PROFINET, PROFIBUS, DeviceNet and CANopen)

Quick commissioning

HVAC Drive H300 portable memory devices: A Smartcard enables simplified maintenance and commissioning without a PC, storing parameters and system upgrades.



*Interact Analysis - Low Voltage AC Motor Drives Report 2020

CASE STUDIES:

AXXA LTD SUPPLIES

UK firm, Axxa LTD supplies automation and motion control products and services internationally.

The company aims to be a helpful partner throughout the procurement process, be it a replacement part to get production lines up and running or specifying the best instrumentation system for a new or existing plant.

The fan motor works at a lower rpm than the old drive and has made a great difference in our restaurant area.

With the new drive, the wall has stopped shaking and the venue is not noisy anymore. From my point of view, this was a very simple project for us. Setting the drive up was very easy. It was up and running, the way we wanted, within half an hour. It was also easy to program; All Star Lanes have excellent support on hand if they ever need it.

Per Lutteman - Director
APS Engineering



Stopped vibrations and noise



Improved customer experience



Halved power consumption and energy bills



TESSIDE POWER STATION

The installation of variable speed drives for fan control in a Cooling tower at Teesside Power Station is reducing downtime, as well as giving the potential for improving overall generating efficiency.



Improved cooling tower performance



Increased power station efficiency



Reduced maintenance

Only one drives company – Control Techniques – could give us the drives features we wanted in a compact package that would fit.

The DOL starters produce mechanical snatch on high-inertia components, whilst, with the variable-speed drives, the fans are started gently and ramped up to its two-speed set-points. Equally, the stop sequence is a pre-determined ramp-down. We expect to see major benefits of reduced maintenance on this quadrant.

Jon Scott - Senior Electrical and Control Engineer
PX LIMITED





**CASE STUDY:
ENHANCED EFFICIENCY
OF UP TO 96%
AT NATIONAL LIBRARY**

The National Library of France (BnF) is the country's biggest library. Its collections comprise fourteen million books and periodicals, as well as a variety of other materials including manuscripts, prints & maps. To protect its valuable collections, BnF must operate an extremely reliable air conditioning system.

The Challenge

BnF had decided to replace an asynchronous variable speed drive assembly with a new drive system that would be used to power an air conditioning HVAC responsible for half of the library's reading rooms. This decision was made after an energy optimisation study showed that the existing application's operating efficiency fell to just 50 % in winter.

The Solution

"The ROI calculation showed that it would make far more sense to swap the asynchronous drive system for high-performance synchronous technology"

Jérôme Hardy
GED ADREM



To handle the variable torque load of the HVAC and ventilation applications, a solution was implemented comprising a LSRPM 250 (85 kW) motor and a Control Techniques variable speed drive unit.

The Benefits

The permanent magnet synchronous motor offers enhanced efficiency of up to 96 % over the whole operating speed range.

Another cost advantage comes from the sensorless control which simulates an encoder input with a high degree of precision. "With this solution, not only do we eliminate the cost of the encoder, but we also reduce the number of components and thus the probability of a breakdown", says Hardy.

Since then, the equipment has been monitored and compared with the data collected during commissioning. This makes it easier to detect drift, premature wear and overconsumption.

The assembly is connected to the BMS (building management system), an automated, centralized supervision system that gives the speed setpoint.

DUST AND WATER RESISTANT HVAC DRIVE H300 HIGH IP VARIANT

The HVAC Drive H300 offers a full IP65 solution with exactly the same dedicated HVAC features & capabilities as the standard models.

IP65 provides protection from total dust ingress and low pressure water jets from any direction, making it a simple choice for harsh environments and the outdoors*. The HVAC Drive H300 is now one of the most protected drives on the market, maximising uptime and productivity, while cutting maintenance costs.

Standard and High IP drives

The High IP drive will already be familiar to users of the HVAC Drive H300, with all the same features that make commissioning effortless. The Hand-Off-Auto keypad with the built-in real-time clock is still available, sealed, and the protective casing has been designed with easy servicing and usability in mind.

This new variant enables customers to use both standard and high IP drives for the same project, so there is no longer any headache with mixing-and-matching vendors or product feature sets, making project qualification straightforward.

Save on installation

The HVAC Drive H300 High IP drive is enclosed in a sturdy, protective yet light casing, providing a compact solution. This not only allows easy integration in harsh environments but wall mounting close to the motor reduces installation costs, through:

- No cabinet required
- Shorter cable lengths
- Less labour time/cost to install drive

Free 5 year warranty

To share our confidence in the reliability of Control Techniques, the HVAC Drive H300 High IP product is also eligible for Control Techniques' extended warranty, at no extra cost.



*Shading to be ensured

Warranty terms and conditions apply.

A photograph of an industrial engine assembly line. Several large, silver-colored engines are mounted on a conveyor system. The background shows a complex network of metal beams and overhead structures, typical of a factory setting. The lighting is bright and even. The text 'COMPACT & RELIABLE' is overlaid in large, white, bold, sans-serif font, centered vertically and horizontally across the image.

**COMPACT
& RELIABLE**

SIMPLE COMMISSIONING FOR HASSLE-FREE, EFFICIENT INSTALLATION

Install and go. Application-focused design mean optimum performance can be achieved straight out of the box, with minimal set-up.

Guided commissioning tool

COMING SOON!

Gain complete control of your drive with Control Techniques' Connect PC Software. The dynamic drive logic diagrams allow the visualisation and control of the drive in real time. The parameter browser enables viewing, editing and saving of parameters as well as importing parameter files.



Guided setup screen within the Connect PC software

Single setup menu

Setup using only the keypad couldn't be easier. There's no need to waste time looking for all the parameters - we've grouped them all together for you in one, streamlined menu.

All relevant parameters are literally at your fingertips to easily configure and monitor your application.

All additional parameters are still accessible through the advanced menus, for un-precedented control and finetuning.

COMING SOON!

FREE STANDING DRIVE RANGE

Ready to use pre-engineered high power drives

Highly efficient pre-engineered motor control system

Control Techniques' Free Standing Drive optimises motor energy efficiency and comes ready to use, pre-assembled in its own industry-standard cabinet with all necessary system components included. The HVAC Drive H300's Free Standing Drive variant complements and extends the product range, while having all of the core product's capabilities & features.

Light weight, but no light weight!

The H300 is also available with Control Techniques' largest frame, which not only offers 500 kW of power in a single module, but at 130 kg is up to 60 kg lighter than competitor drives. Its small footprint and pre-engineered accessories make it easy to install or retrofit in industry-standard cubicles.

No extra engineering required

The Free Standing Drive fits a small footprint, and it's easy to integrate with common cubicles, including as standard: load switch, fuses, fan, line & sharing chokes and cabling. The cabinet can also come with a door-mounted HMI with Real-Time Clock, for easy set-up and maintenance.

Thanks to the dedicated online configurator, getting a quote and ordering is as simple as can be. Even more, we can ship your Free Standing Drive to you at very short lead times, saving weeks on typical industry standards.

Large frame power module in pre-assembled cabinet





CONTROL TECHNIQUES PC TOOLS

Energy savings estimation

Control Techniques' energy optimisation software helps you analyse energy usage for flow applications and quantify the cost savings of using your Control Techniques drive.

- Estimation of energy usage using Control Techniques variable frequency drives for HVAC applications
- Identify the payback period through the energy savings from using a HVAC Drive H300 over conventional control methods



Diagnostic Tool

The Diagnostic Tool App is a fast and simple tool, which allows users to quickly solve any error codes that the drive may show. Built within the app are easy to locate wiring diagrams for first time setup and fault finding with links to the relevant comprehensive manuals.

The app also has full contact details of the technical support teams around the world to aid you with technical assistance.

Available for iOS, Android and WindowsTM, download the app for free at:
www.controltechniques.com/mobile-applications



*For Microsoft users, please note that this mobile app operates with Windows 10 only.

Slot for Smartcard/SD card for parameter storage and cloning

Easy click-in keypad connector

Multi-language LCD keypad

With Hand, Off and Auto controls and built-in real-time clock for run time scheduling

3x System Integration (SI) module slots for communications and I/O**

Onboard I/O

- | | |
|--------------------|---------------------------------|
| 2 x analog inputs | 3 x configurable digital I/O |
| 2 x analog outputs | 2 x form C relay outputs |
| 3 x digital inputs | 1 x Safe Torque Off (STO) input |

**SI-I/O option provides additional 4 x digital I/O, 3 x analog inputs (default)/digital inputs, 1 x analog output (default)/digital input, 2 x relays

User-friendly pluggable control connections



*Features and their locations vary on some drive sizes

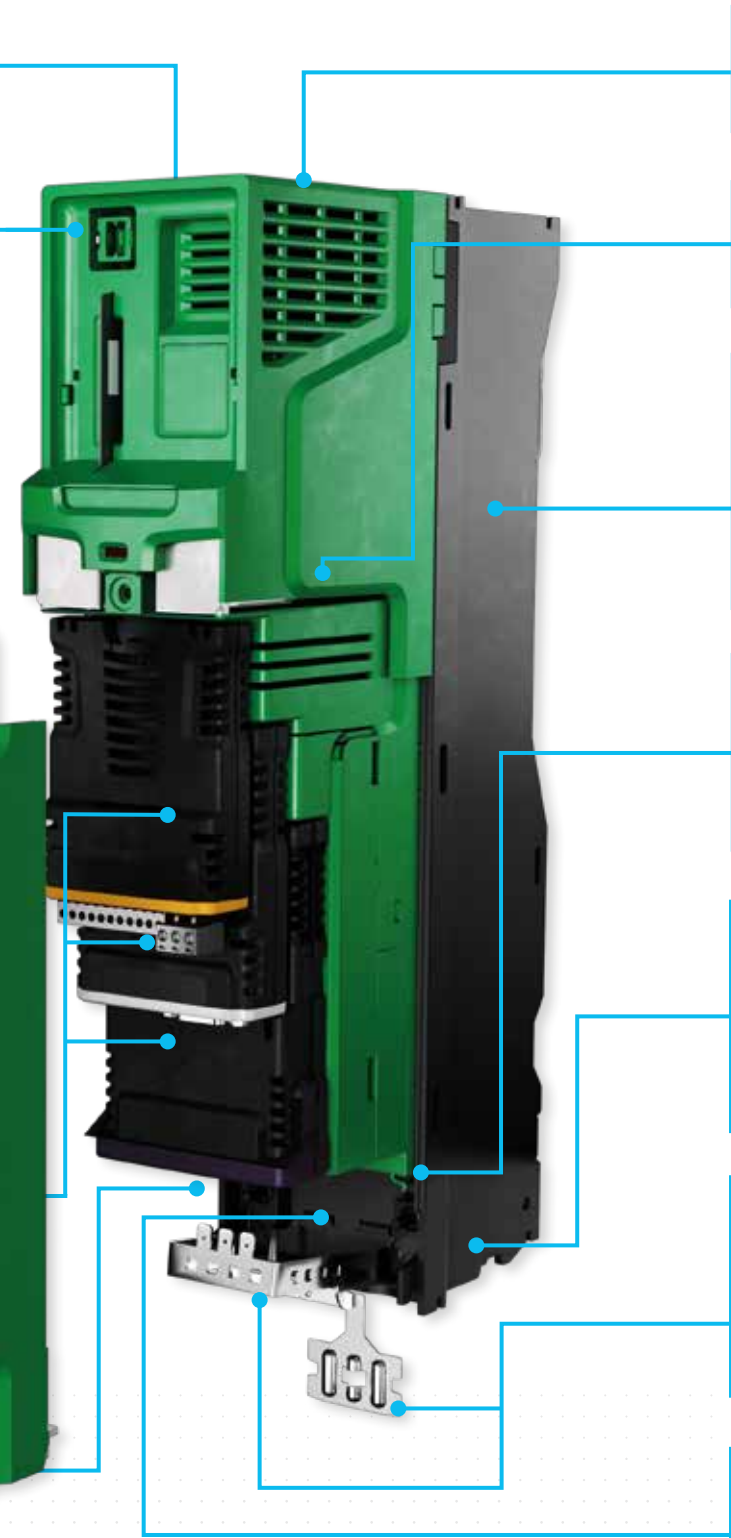

Onboard EMC filter*

Conformal coating as standard

Aluminium chassis
Allows flexible mounting, with high performance extruded heatsink.

User-friendly power connections
With removable terminals*.

Adaptive multi-speed fan control
The fan can also be replaced by the user after installation

Robust cable management system
Grounding point for shielded control and power cables

3-pin RS485 Modbus communications as standard

HVAC DRIVE H300

ORDERING GUIDE

Normal duty operation only

Suitable for HVAC applications, with a current overload requirement of 110% for 60 s*.

Conformance

- IP20 / NEMA1 / UL TYPE 1 *UL open class as standard, additional kit needed to achieve Type 1
- IP65 / NEMA4 / UL TYPE 12 rating is achieved on the rear of the drive when through panel mounted
- *Frame size 9D, 9E, 10D and 10E achieve IP55 / NEMA 4 / UL Type 12
- Ambient temperature -20 °C to 40 °C (-4 °F to 104 °F) as standard. Up to 55 °C (131 °F) with derating
- Humidity 95 % maximum (non-condensing) at 40 °C (104 °F)
- Altitude: 0 to 3000 m (9900 ft), derate 1 % per 100 m (330 ft) between 1000 m (3300 ft) and 3000 m (9900 ft)
- Random Vibration Tested in accordance with IEC 60068-2-64
- Bump Tested in accordance with IEC 60068-2-29
- Sinusoidal Vibration Tested in accordance with IEC 60068-2-6
- Mechanical Shock Tested in accordance with IEC 60068-2-29
- Storage temperature -40 °C to 55 °C (-40 °F to 131 °F) or up to 70 °C (158 °F) for short-term storage
- Electromagnetic Immunity complies with EN 61800-3 and EN 61000-6-2
- With onboard EMC filter, emissions comply with EN 61800-3 (category C3)
- EN 61000-6-3 and EN 61000-6-4 with optional footprint EMC filter
- IEC 60146-1-1 Supply conditions (category C1 or C2 depending on rating)
- IEC 61800-5-1 (Electrical Safety)
- IEC 61131-2 I/O
- EN 61000-3-12 with optional line reactor
- UL 508C (Electrical Safety)

Keypads

Description	Order code
KI-HOA Keypad RTC H300	82400000018500
Remote HOA Keypad RTC	82400000019700
KI-485 Adaptor	82400000016100

Dimensions



Frame size	Dimensions		Weight
	mm (HxWxD)	in (HxWxD)	
3	382 x 83 x 200	15.0 x 3.3 x 7.9	4.5 (9.9)
4	391 x 124 x 200	15.4 x 4.9 x 7.9	6.5 (14.3)
5	391 x 143 x 200	15.4 x 5.6 x 7.6	7.4 (16.3)
6	391 x 210 x 227	15.4 x 8.3 x 8.9	14 (30.9)
7	557 x 270 x 280	21.9 x 10.6 x 11.0	28 (61.7)
8	803 x 310 x 290	31.6 x 12.2 x 11.4	50 (110.2)
9A	1108 x 310 x 290	43.6 x 12.2 x 11.4	66.5 (146.6)
9E/10E	1069 x 310 x 290	42.1 x 12.2 x 11.4	46 (101.4)
9D/10D	Rectifier 355 x 310 x 290	Rectifier 15.8 x 12.2 x 11.4	12 (26.5)
	Inverter 773 x 310 x 290	Inverter 30.4 x 12.2 x 11.4	34 (75)
11E	1242 x 310 x 312	48.9 x 12.2 x 12.3	63 (138.9)
12T	1750 x 295 x 526	68.9 x 11.6 x 20.7	130 (287)

High IP	Dimensions		Weight
	mm (HxWxD)	in (HxWxD)	
Frame 03	572 x 256 x 221	22.5 x 10.1 x 8.7	7.5 (16.5)
Frame 04	566 x 256 x 221	22.3 x 10.1 x 8.7	9.3 (20.5)
Frame 05	570 x 256 x 221	22.5 x 10.1 x 8.7	10.0 (22.0)
Frame 06	575.5 x 317 x 221	22.7 x 12.5 x 9.8	16.9 (37.3)

*For more detailed information please see technical documents.

HVAC DRIVE H300

MODEL NUMBER AND RATINGS

200/240 Vac ±10%					380/480 Vac ±10%				
Product Code	Normal Duty				Product Code	Normal Duty			
	IP20 Max continuous current (A)	Motor shaft power (kW)	Motor shaft power (hp)	IP65 Max continuous current (A)		IP20 Max continuous current (A)	Motor shaft power (kW)	Motor shaft power (hp)	IP65 Max continuous current (A)
H300-03200066A	6.6	1.1	1.5	6.6	H300-03400034A	3.4	1.1	1.5	3.4
H300-03200080A	8	1.5	2	8	H300-03400045A	4.5	1.5	2	4.5
H300-03200110A	11	2.2	3	11	H300-03400062A	6.2	2.2	3	6.2
H300-03200127A	12.7	3	3	12.7	H300-03400077A	7.7	3	5	7.7
H300-04200180A	18	4	5	18	H300-03400104A	10.4	4	5	10.4
H300-04200250A	25	5.5	7.5	22	H300-03400123A	12.3	5.5	7.5	11
H300-05200300A	30	7.5	10	30	H300-04400185A	18.5	7.5	10	18.5
H300-06200500A	50	11	15	50	H300-04400240A	24	11	15	21
H300-06200580A	58	15	20		H300-05400300A	30	15	20	29
H300-07200750A	75	18.5	25		H300-06400380A	38	18.5	25	38
H300-07200940A	94	22	30		H300-06400480A	48	22	30	48
H300-07201170A	117	30	40		H300-06400630A	63	30	40	
H300-08201490A	149	37	50		H300-07400790A	79	37	50	
H300-08201800A	180	45	60		H300-07400940A	94	45	60	
H300-09202160A	216	55	75		H300-07401120A	112	55	75	
H300-09202660A	266	75	100		H300-08401550A	155	75	100	
H300-09202160E	216	55	75		H300-08401840A	184	90	125	
H300-09202660E	266	75	100		H300-09402210A	221	110	150	
H300-10203250E	325	90	125		H300-09402660A	266	132	200	
H300-10203600E	360	110	150		H300-09402210E	221	110	150	
					H300-09402660E	266	132	200	
					H300-10403200E	320	160	250	
					H300-10403610E	361	200	300	
					H300-11404370E	437	225	350	
					H300-11404870E	487	250	400	
					H300-11405070E	507	280	450	

Manuals

H300 is supplied with a Step-by-Step Setup Guide to assist with fast, efficient commissioning. A detailed user guide is also available to download online, or can be requested from Control Techniques Drive Centres and Partners.

380/480 Vac ±10%				
Product Code	Normal Duty			IP65 Max continuous current (A)
	IP20 Max continuous current (A)	Motor shaft power (kW)	Motor shaft power (hp)	
H300-12404800T	608	315	500	
H300-12405660T	660	355	550	
H300-12406600T	755	400	650	
H300-12407200T	865	500	700	

500/575 Vac ±10%				
Product Code	Normal Duty			IP65 Max continuous current (A)
	IP20 Max continuous current (A)	Motor shaft power (kW)	Motor shaft power (hp)	
H300-05500039A	3.9	2.2	3	3.9
H300-05500061A	6.1	4	5	6.1
H300-05500100A	10	5.5	7.5	10
H300-06500120A	12	7.5	10	12
H300-06500170A	17	11	15	17
H300-06500220A	22	15	20	22
H300-06500270A	27	18.5	25	27
H300-06500340A	34	22	30	34
H300-06500430A	43	30	40	
H300-07500530A	53	37	50	
H300-07500730A	73	45	60	
H300-08500860A	86	55	75	
H300-08501080A	108	75	100	
H300-09501250A	125	90	125	
H300-09501550A	155	110	150	
H300-09501250E	125	90	125	
H300-09501500E	150	110	150	
H300-10502000E	200	130	200	
H300-11502480E	248	175	250	
H300-11502880E	288	225	300	
H300-11503150E	315	250	350	

500/690 Vac ±10%				
Product Code	Normal Duty			IP65 Max continuous current (A)
	IP20 Max continuous current (A)	Motor shaft power (kW)	Motor shaft power (hp)	
H300-07600230A	23	18.5	25	
H300-07600300A	30	22	30	
H300-07600360A	36	30	40	
H300-07600460A	46	37	50	
H300-07600520A	52	45	60	
H300-07600730A	73	55	75	
H300-08600860A	86	75	100	
H300-08601080A	108	90	125	
H300-09601250A	125	110	150	
H300-09601500A	150	132	175	
H300-09601250E	125	110	150	
H300-09601550E	155	132	175	
H300-10601720E	172	160	200	
H300-10601970E	197	185	250	
H300-11602250E	225	200	250	
H300-11602750E	275	250	300	
H300-11603050E	305	280	400	

PRODUCT CODE STRUCTURE

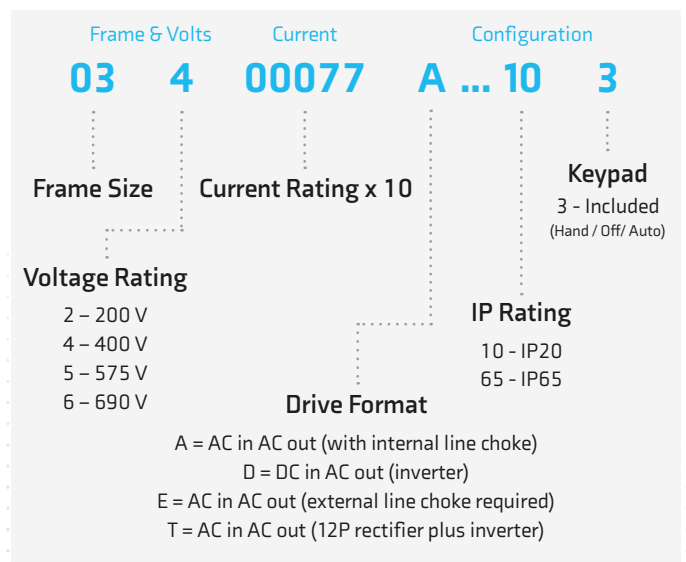

Note: Higher Power Ratings are available with modular drive solutions

ACCESSORIES ORDERING GUIDE

Comprehensive options for flexibility

Keypad type		Description
KI-HOA Keypad RTC - Green (Supplied as standard*)		The KI-HOA Keypad RTC provides Hand-Off-Auto control. The display presents up to four lines of real text with multi-language translation, enhancing clarity and increasing ease of use. A battery operated real-time clock allows scheduling of run and off periods and adds accurate time stamping to diagnostics to aid rapid fault resolution
Remote HOA Keypad RTC		Remote mountable keypad, allowing flexible mounting on the outside of a panel (meets IP54/NEMA 12). The keypad offers Hand-Off-Auto control and can present up to four lines of real text with multi-language translation, enhancing clarity and increasing ease of use. Battery operated real-time clock allows scheduling of run and off periods and adds accurate time stamping to logged events, aiding diagnostics
KI-485 Adaptor		This adaptor can be fitted in place of the drive keypad and provides additional ports to communicate via RS485. The adaptor is commonly used for programming the drive.
System Integration Modules - Communications		
SI-Ethernet		External Ethernet module that supports EtherNet/IP and Modbus TCP/IP and has an integrated web server that can generate emails. The module can be used to provide high speed drive access, global connectivity and integration with IT network technologies, such as wireless networking. To use multiple H300 drives in Multi-leader mode in a parallel HVAC system, each H300 drive must have an SI-Ethernet module fitted.
SI-EtherCAT		SI-EtherCAT allows H300 to connect and interface with EtherCAT networks.
SI-PROFINET		SI-PROFINET allows H300 to communicate and interface with PROFINET PLCs and networks.
SI-PROFIBUS		PROFIBUS interface module PROFIBUS-DP (Decentralized Peripheral) interface module enables follower connectivity. It is possible to use more than one SI-PROFIBUS or a combination of SI-PROFIBUS and other option modules to add additional functionality such as extended I/O, gateway functionality, or additional PLC features
SI-DeviceNet		DeviceNet networking system interface module enables follower connectivity. It is possible to use more than one SI-DeviceNet or a combination of SI-DeviceNet and other option modules to provide additional functionality such as extended I/O, gateway functionality, or additional PLC features
SI-CANopen		CANopen interface module supporting various profiles, including several drive profiles
SI-POWERLINK		POWERLINK interface module supporting all AC drive families and conforming to the latest POWERLINK standard.
MCI200		Second processor, providing advanced customisation using standard IEC61131-3 programming languages
Additional I/O and NV media cards		
SI-I/O		Extended I/O interface module to increase the number of I/O points on a drive. Provides additional: 4 x Digital I/O, 3 x Analog inputs (default)/Digital inputs, 1 x Analog output (default)/Digital input, 2 x Relays
Smartcard		The optional Smartcard memory device can be used to back-up parameter sets, as well as copying them from one drive to another
SD Card Adaptor		Conversion device that allows an SD card to be inserted into the Smartcard slot, for parameter cloning and application programs

*For higher cost efficiency, H300 can be supplied without a keypad. Please specify your preference when ordering.

ACCESSORIES ORDERING GUIDE

Retrofit brackets

To allow an H300 to be fitted in existing Unidrive SP and Affinity surface mount installations.

Frame size	Order code
4	3470-0062
5	3470-0066
6	3470-0074
7	3470-0078
8	3470-0087
9A, 9E, & 10	3470-0118

Through-hole IP65 kits

Frame size	Order code
3	3470-0053
4	3470-0056
5	3470-0067
6	3470-0055
7	3470-0079
8	3470-0083

Through-hole IP55 kits

Frame size	Order code
9A	3470-0119
9E/10E	3470-0105
10 Inverter	3470-0108
10 Rectifier	3470-0106
11E & 11T	3470-0126
11D Inverter	3470-0130
11 Rectifier	3470-0123

Option modules

Option module	Order code
SI-PROFIBUS	82400000017500
SI-Ethernet	82400000017900
SI-EtherCAT	82400000018000
SI-DeviceNet	82400000017700
SI-CANopen	82400000017600
SI-POWERLINK	82400000021600
SI-PROFINET RT	82400000018200
MCI200	82400000017000
SI-I/O	82400000017800

Tile mount kit

Frame size	Order code
3	3470-0049
4	3470-0060
5	3470-0073

General kit items

Item	Order code
Frame size 3 & 4 power connector split kit	3470-0064

Optional media and accessories

Description	Order code
SD-Smartcard Adaptor	3470-0047
Smartcard (64KB)	2214-0010

ACCESSORIES ORDERING GUIDE

DC bus paralleling kits

Frame size	Order code
3	3470-0048
4	3470-0061
5	3470-0068
6	3470-0063
6 (connect to frame 3,4 & 5)	3470-0111

Line reactors

Frame size	Order code
9E 200 V/400 V	4401-0181
9E 575 V/690 V	4401-0183
10E 200 V/400 V	4401-0182
10E 575 V/690 V	4401-0184

UL type 1 conduit kits

Frame size	Order code
3&4	6521-0071
5	3470-0069
6	3470-0059
7	3470-0080
8 & 9A	6500-0106
9E & 10E	3470-0115
11	3470-0136

Optional external EMC filters

The H300's built-in EMC filter complies with EN 61800-3*. External EMC filters are required for compliance with EN 61000-6-4.

Frame size	Voltage	Order code
3	200 V	4200-3230
	400 V	4200-3480
4	200 V	4200-0272
	400 V	4200-0252
5	200 V	4200-0312
	400 V	4200-0402
	575 V	4200-0122
6	200 V	4200-2300
	400 V	4200-4800
	575 V	4200-3690
7	200 V	4200-1132
	400 V	4200-1132
	575 V	4200-0672
	690 V	4200-0672
8	200 V	4200-1972
	400 V	4200-1972
	575 V	4200-1662
9A	690 V	4200-1662
	200 V	4200-3021
	400 V	4200-3021
	575 V	4200-1660
9E & 10E	690 V	4200-1660
	200 V	4200-4460
	400 V	4200-4460
11	575 V	4200-2210
	690 V	4200-2210
	400 V	4200-0400
	575 V & 690 V	4200-0690

*For more detailed information please see technical documents.

DRIVE OBSESSED



Control Techniques has been designing and manufacturing the best variable speed drives in the world since 1973.

Our customers reward our commitment to building drives that outperform the market. They trust us to deliver on time every time with our trademark outstanding service.

More than 45 years later, we're still in pursuit of the best motor control, reliability and energy efficiency you can build into a drive. That's what we promise to deliver, today and always.

1.4K+

Employees

70

Countries

#1 FOR ADVANCED MOTOR AND DRIVE TECHNOLOGY



Nidec Corporation is a global manufacturer of electric motors and drives.

Nidec was set up in 1973. The company made small precision AC motors and had four employees. Today, it's a global corporation that develops, builds and installs cutting-edge drives, motors and control systems in over 70 countries with a workforce of more than 110,000.

You'll find its innovations in thousands of industrial plants, IoT products, home appliances, cars, robotics, mobile phones, haptic devices, medical apparatus and IT equipment all over the world.

109K

Employees

\$14.6B

Group Turnover

70+

Countries

330+

Companies



CONTROL TECHNIQUES IS YOUR GLOBAL DRIVES SPECIALIST.

With operations in over 70 countries, we're open for business wherever you are in the world.

For more information, or to find your local drive centre representatives, visit:

www.controltechniques.com

Connect with us



©2020 Nidec Control Techniques Limited. The information contained in this brochure is for guidance only and does not form part of any contract. The accuracy cannot be guaranteed as Nidec Control Techniques Ltd have an ongoing process of development and reserve the right to change the specification of their products without notice.

Nidec Control Techniques Limited. Registered Office: The Gro, Newtown, Powys SY16 3BE.

Registered in England and Wales. Company Reg. No. 01236886.

0781-0425-01 01/21

